



BALTEX

Newsletter

No. 10

October 2007

World Climate Research Programme / Global Energy and Water Cycle Experiment
WCRP
GEWEX

5th Study Conference in Estonia

Joakim Langner (joakim.langner@smhi.se), Chair BALTEX Science Steering Group (BSSG), *Hans-Jörg Isemer* (isemer@gkss.de), Head International BALTEX Secretariat

With more than 140 registered participants from 16 countries and 120 papers presented (of which 65 were oral presentations and 55 given as posters), the 5th Study Conference on BALTEX was successfully conducted in Kuressaare, Estonia. The full Conference program and proceedings as well as additional information are available at www.baltex-research.eu/conf2007/.

Continued on page 2



Co-operation between HELCOM and BALTEX: A fruitful science-policy dialogue

The Ecosystem Approach of HELCOM, adopted in 2003, requires that the best available scientific information is used as a basis for HELCOM work. The recently published HELCOM Assessment of Climate Change in the Baltic Sea area, which is based on the BALTEX Assessment of Climate Change for the Baltic Sea basin (BACC), is an excellent example of how such scientific advice can be obtained.

Article on page 3



Participants of the 5th Study Conference on BALTEX in front of the historic Kuressaare Town Hall on 5 June 2007

Contents

5 th Study Conference on BALTEX in Estonia.....	1	A simulation of POC in the southern Baltic Sea.....	10
Fruitful BALTEX-HELCOM co-operation.....	3	Seasonal snow storage variations over northern Europe.....	12
BALTEX Phase II Data Management directions.....	4	Validation of cloud climate simulations by satellite data.....	13
An inventory of Baltic Sea biogeochemical models.....	5	Storm surges in the Gulf of Riga.....	15
Oceanography of the northern Kvarik Strait.....	6	Recent BALTEX publications.....	18
Baltic Sea water temperature and winter water formation.....	7	Conference Announcements.....	19

Continued from page 1

The entire spectrum of BALTEX Phase II research including neighbouring areas and the involvement of stakeholders were covered. About 75 % of all papers were addressing the objectives which are new in the frame of phase II of BALTEX, an encouraging indicator for the present and future development of the programme.

The conference reflected the wider scope of BALTEX Phase II with much stronger contributions in climate and environmental topics than during previous conferences, and there were many opportunities to discuss how further work in this direction could be stimulated.

The strong focus on climate and climate modelling and impacts of climate change continues. It is clear that BALTEX makes excellent contributions to its mother programmes GEWEX/CEOP and WCRP, as was impressively outlined by related presentations given in the opening session of the Conference. It is also obvious that BALTEX is already moving beyond the scope of these programmes, particularly in areas where air and water quality issues are addressed. Outputs from climate models are being used for more detailed studies affecting a large cross section of sectors within society, leading to challenges in communication of scientific results. Climate change and related impacts are also prominent areas where the outreach of BALTEX has recently become increasingly effective through the close cooperation with the Helsinki Commission (HELCOM). HELCOM used the Conference to express its wish for a continuous cooperation with BALTEX to assess even better the impacts of climate change on the Baltic Sea ecosystem (see also article on page 3).

The political dimension and importance of in particular the climate-related aspects of the BALTEX program were clearly highlighted by three welcome addresses in the opening session of the Conference, when both expectations and awareness related to environmental information needed for decision making at different levels (the European, national Estonian and local levels) were pointed out by representatives of the European Parliament, the national Estonian Ministry of the Environment, and the mayor of the hosting city Kuressaare.

The Conference enjoyed good contributions from several research programmes and networks such as LOICZ, EUROCEANS and ENSEMBLES, and a strengthened interaction between BALTEX and these networks is one way forward towards the broader objectives of BALTEX Phase II. Cooperation and integration with such networks should be pursued but BALTEX needs to define its focus along the Implementation Plan and define interfaces and linkages to other activities, which allow for organised cooperation without losing the BALTEX identity.



Estonian BALTEX Science Steering group members Sirje Keevallik (centre left) and Jüri Elken (centre right) welcome European Parliament member Andres Tarand (left) and Raivo Kallas of the Estonian Ministry of the Environment (right)

Coupling and off-line modelling of biology and chemistry both on land, ocean, and atmosphere were presented. BALTEX researchers are increasingly involved in CO₂ science with both observational and modelling activities. Better tools and methods for dynamic analyses of ecosystem impacts to climate variability and change are emerging. The building blocks for regional Earth System Models are available and the first steps towards such model development have been taken.

The Conference also demonstrated case studies on how research knowledge is further developed and processed for decision making: the ASTRA project and several regional and local studies addressed within the COASTMAN project showed the transfer of research knowledge to practical application in areas related to climate change and coastal zone management in regions of the Baltic Sea Basin.

The Conference was also used for group meetings and workshops, among them a regular two-days meeting of the BALTEX Working Group Radar and an evening workshop on present and future data management in BALTEX. Presentations given at the latter workshop spanned an introduction to the BALTEX data management web site, which acts as portal for all BALTEX data management issues (www.baltex-research.eu/data), an overview over BALTEX Phase II data management future directions, including a presentation of the relevant data portals UNIDART and CERA (see also article on page 4). Furthermore, the access to CEOP data was explained, and a comprehensive data portal to worldwide climate data, the Climate Explorer, was presented.

The organisation of the Conference ran smoothly thanks to the professional preparations and on-site management by the BALTEX Secretariat and the local organisers. The perfect weather and the attractive local surroundings contributed to a good and relaxed spirit.

www.baltex-research.eu/conf2007

Co-operation between HELCOM and BALTEX: A fruitful science-policy dialogue



Hermanni Backer (*hermanni.backer@helcom.fi*), **Juha-Markku Leppänen** (*juha-markku.leppanen@helcom.fi*), HELCOM Secretariat, Helsinki, Finland, **Janet Pawlak** (*jpawlak@dahm.dk*), Marine Environmental Consultants, Charlottenlund, Denmark

HELCOM has served as a bridge between science and policy for the Baltic marine environment since the Helsinki Convention was signed in 1974. The Ecosystem Approach, adopted in 2003, requires that the best available scientific information is used as a basis for HELCOM work; an example of this is the HELCOM Baltic Sea Action Plan, to be agreed by a Ministerial Meeting in November 2007. The production of the recently published HELCOM Assessment of Climate Change in the Baltic Sea area (Baltic Sea Environment Proceedings No. 111) is an excellent example of how such scientific advice can be obtained. This exercise in science-policy dialogue is special as it has avoided mixing science and policy at too early a stage, which is a common pitfall of many other climate assessments. Instead, a separate joint exercise to condense the information included in a bulky scientific document, the BALTEX Assessment of Climate Change for the Baltic Sea basin (BACC), has been carried out and, of equal importance, the output has been presented to, and approved by, the original BACC group.

Ecosystem Approach requires that the effects of climate change are included in the commitments towards a healthy Baltic Sea, for example, in the further development of reduction targets for nutrient emissions. For this reason, the next phase of BALTEX, with its aims to broaden its scope from purely physical issues to ecosystem impacts of climate change, is very interesting for HELCOM processes. Due to the central position that ecosystem models have taken in the present work of HELCOM, discussions are ongoing about a wide cooperation between Baltic ecosystem modellers to ensure that the differences in model estimates and modeller opinions are taken into account when preparing further policy actions. The BALTEX community is a natural gathering place for modelling people and is a valuable partner for HELCOM in these developments.



The HELCOM climate change assessment has paved the way for further assessment cooperation between HELCOM and BALTEX. In case a second assessment will be prepared within the BALTEX group, HELCOM secretariat is willing to be closely involved in this process. In particular, the prospects of further developing the estimates of potential ecosystem impacts are central to enable full use of the climate change information in regional environmental policy.

The fruitful BALTEX-HELCOM cooperation has been a refreshing reminder that good cooperation between producers of scientific knowledge and policy processes is possible. This is in itself remarkable as it is not difficult to imagine a less desirable result in circumstances with less scientific rigor and more political passions. Such, unfortunately widespread, communication difficulties between science and policy are in many ways linked to the way future scientists and policymakers are educated. For scientists, policy-relevant science does not mean that scientists give up their scientific integrity, but rather that they develop the aptitude to look at their results in a slightly different light. In order to foster further this kind of positive attitude to the opportunities of participating in policy-making, the possibility of arranging joint HELCOM

and BALTEX summer schools to introduce PhD students to regional assessment work is being investigated. Young scientists will learn that the appropriate use of scientific results in the development of policy is a valuable use of scientific output and an important contribution to environmental protection.

The strong scientific basis of BALTEX ensures the production of solid scientific advice for regional environmental policymaking such as the agreements reached within HELCOM. Without the activity of groups like BALTEX, the HELCOM Ecosystem Approach would quickly lose its scientific footing, and thus its justification as a meaningful leading principle for regional policy in the Baltic Sea area.

www.helcom.fi

BALTEX Phase II Data Management Directions

Michael Lautenschlager (*michael.lautenschlager@zmaw.de*), *World Data Center for Climate (WDCC), Hamburg, Germany*

BALTEX data management directions were discussed recently at the BALTEX Scientific Steering Group meeting in St. Petersburg (December 2006), at the meeting of the BALTEX Data Management Working Group in Hamburg (April 2007), and at a special workshop during the 5th Study Conference on BALTEX in Kuressaare, Estonia in June 2007. Basically, it was decided to migrate from the centralised BALTEX Phase I data centres to a new data management structure, which is based on networking between already existing BALTEX related databases. A federation of operational, long-term data archives is envisaged.

The BALTEX Phase II data management system will be realised in three steps:

1. A web-list is maintained of those data archives which are relevant for BALTEX research. The web-list is fostered by the International BALTEX Secretariat and provides information on available data sets and their access procedures (www.baltex-research.eu/data/data_links.html, see Fig. 1).

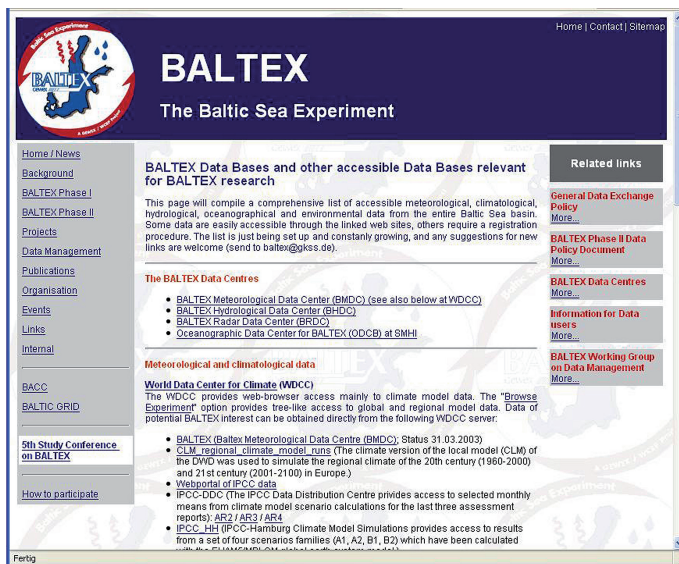

Fig. 1. List of BALTEX related databases at the programme web site (www.baltex-research.eu/data/data_links.html)

2. The next step will be a common BALTEX data catalogue. This web-based catalogue will allow for central search on available BALTEX related data sets. Besides information on the data themselves (metadata), detailed access information will be provided.

3. The third and last step will be the realisation of a BALTEX data portal which allows for “one-stop-shop” data access. The BALTEX data portal will include the BALTEX data catalogue as well as transparent access to geographically distributed data archives.

Presently, two data infrastructures are open to integrate BALTEX related data: the UNIDART system which is maintained and supported by the Deutscher Wetterdienst (DWD – German Weather Service, see Fig. 2) and the ICSU World Data Center Climate (WDCC) at the Max-Planck Institute for Meteorology (MPI-M) and the Deutsches Klimarechenzentrum (DKRZ – German Climate Computing Centre, see Fig. 3).

UNIDART Usage Scenario

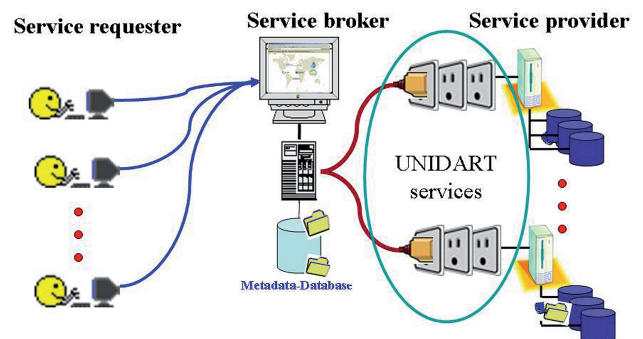

Fig. 2: The UNIDART system for data related to weather services (URL: <http://www.dwd.de/UNIDART>)

The UNIDART system (www.dwd.de/UNIDART) has been developed to disseminate data from European weather services. Presently, the UNIDART system contains operational meteorological observations from Germany, Norway, Finland and Sweden. The access procedure for BALTEX scientists is described on the BALTEX data management web site (www.baltex-research.eu/data), see also box at the end of this article. The UNIDART system is already a “one-stop-shop” realisation of distributed data archives and it is open to integrate new data archives. These data archives have to implement the UNIDART client software and have to register their services and data products in the central UNIDART metadata catalogue. Emphasis is on services and products.

The CERA (Climate and Environmental Data and Archiving Infrastructure) database system of the WDCC (<http://cera.wdc-climate.de>) emphasises the management of research data, from numerical models and related observations. It allows for flexible integration of metadata and scientific data or alternatively of links to scientific data. Like the UNIDART system, the WDCC is open to integrate new BALTEX related data archives into its existing infrastruc-

ture. Data have to be registered in the metadata catalogue. The scientific data can be integrated into the WDC as they are. Access procedures are given in the CERA WWW gateway (<http://cera.wdc-climate.de>).

WDC Climate Data Network

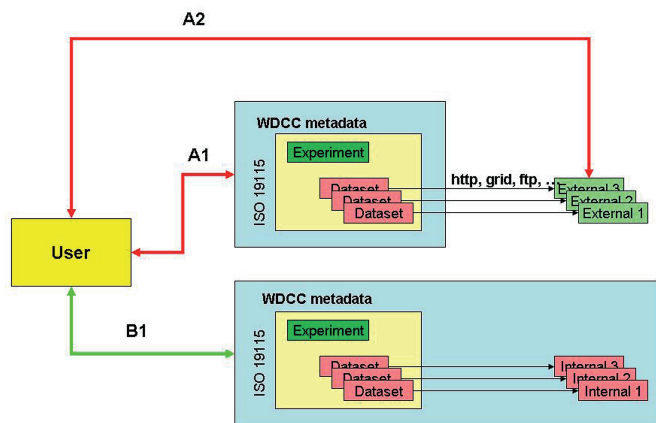

Fig. 3. The World Data Center Climate for data related to research (cera.wdc-climate.de)

The web-list of existing BALTEX related data archives and the BALTEX data architecture candidates (UNIDART and WDC) are open to integrate BALTEX relevant data. For data submission into the BALTEX Phase II data system please contact the BALTEX Secretariat (baltex@gkss.de), or the BALTEX Working Group on Data Management (www.baltex-research.eu/organisation/bwgd.html).

BALTEX scientists and researchers can apply for a WebWerdis web account (Weather Request and Distribution System of the German Weather Service DWD). This is the gateway to the UNIDART database. For registration to this „one-stop-shop“, send an E-mail to the BALTEX secretariat (baltex@gkss.de) if you are already a registered user of BALTEX databases. If you are not a registered BALTEX data user, you need to follow the registration procedure described on the BALTEX web site (www.baltex-research.eu/data/information.html). Once you are registered, you will be provided with further access information.

www.baltex-research.eu/data

www.baltex-research.eu/projects

Towards an Inventory of Biogeochemical Models in the Baltic Sea basin

Marcus Reckermann (reckermann@gkss.de)

International BALTEX Secretariat, GKSS Research Centre Geesthacht, Germany

BALTEX is rooted in the abiotic disciplines hydrology, meteorology and oceanography, for which sophisticated model systems have been developed. New foci of BALTEX Phase II are the integration of climate variability and change aspects, and the outreach towards the biogeochemical and ecological science communities in order to arrive at a better integrative description of the Baltic Sea basin environment. An important goal in this respect is to foster the development of coupled model systems which integrate climatic change and its impact on the marine and terrestrial biota in the Baltic Sea basin.

In order to endorse a better communication and collaboration between the physical and biogeochemical modelling communities, a survey on ongoing biogeochemical modelling activities in the Baltic Sea area has been initiated by the BALTEX Secretariat. Based on personal contacts and internet research, 75 scientists in the Baltic Sea basin were addressed and asked to fill in a questionnaire, in which the model should be described in a general manner.

The results of this survey are available on the BALTEX web site (see below). This list of models is based on the 15 returns which we have received so far (20% “recovery rate”). The models are ordered alphabetically according to their acronyms, and the linked pdf files contain summary information on the model as well as contacts and web links. This list is meant to be dynamic, and it is our hope that it will grow, as more and more modellers take advantage of this platform.

If you are interested to have your model/project to be added to the list of model descriptions, please download the blank questionnaire (available on the web site, see below), fill it in and send it to baltex@gkss.de. Your participation will contribute to more transparency, and a better communication between the different working groups who are active in biogeochemical modeling in the Baltic Sea area.

See also the EUR-OCEANS “Model Shopping tool” with a marine and global focus with some regional Baltic Sea models: www.eur-oceans.eu/integration/wp3.1/shopping_tool/

Research Articles

The Northern Kvark Strait: an important and unknown strait

Anders Omstedt (anders.omstedt@gvc.gu.se), Göteborg University, Earth Sciences Centre, Oceanography

The Northern Kvark Strait is a little understood region of the Baltic Sea. The area constitutes a threshold between two basins, the Bothnian Sea and Bothnian Bay (Fig. 1). Many processes are governed by the properties of this threshold. Conditions in the Northern Kvark Strait affect the ways in which water, nutrients, carbon and environmental toxins are transported into and out of Bothnian Bay.

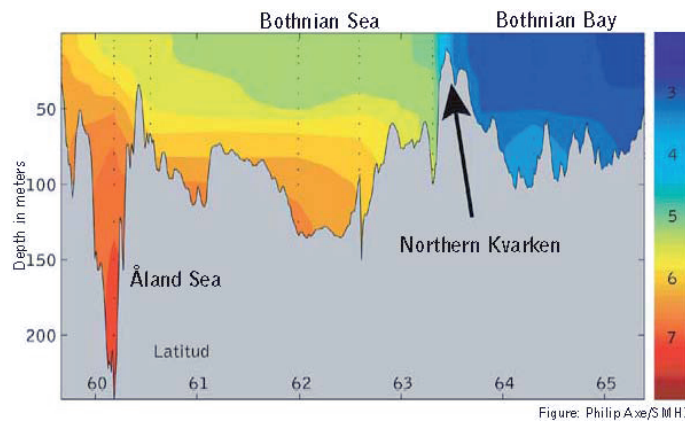

Fig. 1. Many processes are governed by the Northern Kvark Strait oceanographic properties. The picture shows a cross-section from the Åland Sea to northern Bothnian Bay, with the depth scale on the left. The coloured scale indicates salinity, ranging from blue (2 per mille) to red (8 per mille)

The almost fresh waters of Bothnian Bay meet the more saline waters of the Bothnian Sea in the Northern Kvark Strait. River water from the north is transported into the Bothnian Sea through the two sounds of the West and East

Kvark (Fig. 2). A good understanding of the processes is essential when trying to model salinity, temperature and currents in the two basins.

The region is interesting in many respects. The land is rising at a rate of about 8 mm per year, meaning that in 2,500 years there may be a land bridge between Sweden and Finland that passes over the Northern Kvark. This process could happen faster or slower, depending on climatic change.

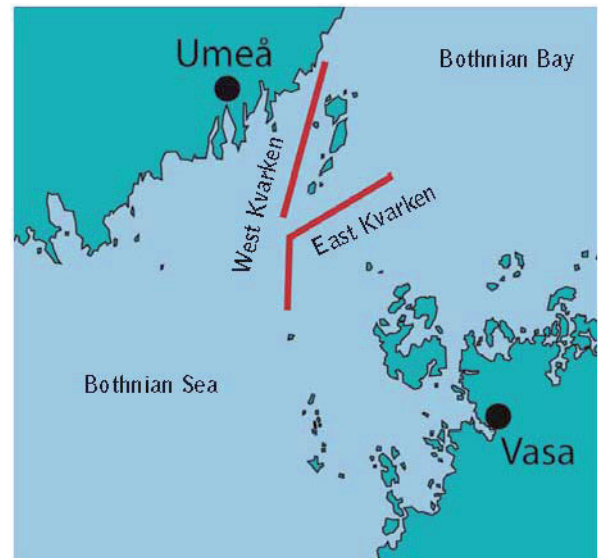

Fig. 2. Two channels carry water into and out of Bothnian Bay (Western and Eastern Kvark straits), passing on both sides of the Holm Islands. The maximum depth of the channels is 25 meters. Measurements were made here to learn more about water exchange between the two basins.

Actual measurements needed

When I was modelling the Baltic Sea in the 1990s, it proved difficult to model Bothnian Bay properly. The salinity calculations showed unrealistically low values. The problem was that the oceanographic conditions in the Northern Kvark Strait and the ways in which they should be modelled were not understood.

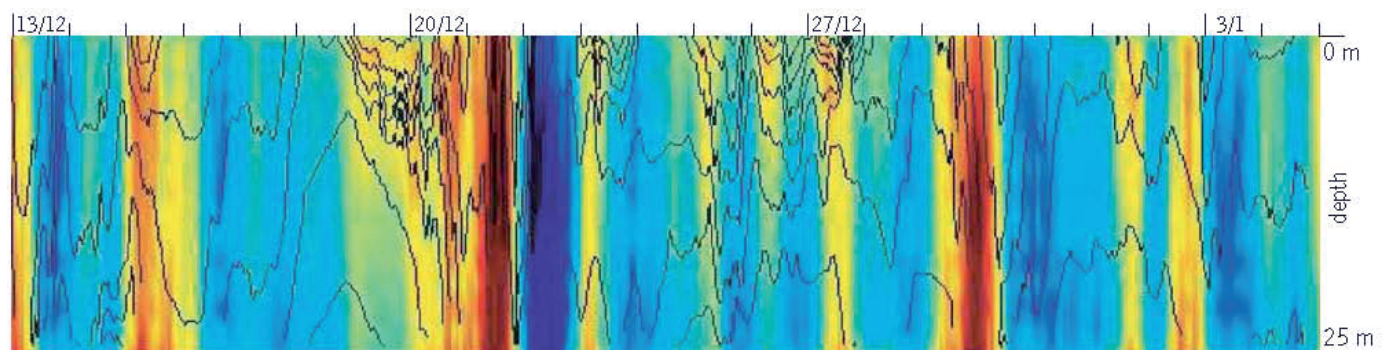

Fig. 3 Flow rates, measured hourly, in the West Kvark Strait at the end of 2004. Time is plotted on the horizontal scale, depth on the vertical scale. The currents range between northerly (red) and southerly (blue), and flow at up to 0.5 m/s. Note the rapid changes in flow direction, and the consistency of the currents all the way from the surface to the bottom. Thin lines indicate density differences (from Green, Liljebladh and Omstedt 2006)

This piqued my interest in this northern oceanic region. Then, a colleague (Stigebrandt 2001) made an interesting suggestion. The suggestion was essentially that flow through the Northern Kvarf Strait is determined by this threshold, across which surface water flows out of Bothnian Bay, while heavier bottom water flows in. He also suggested that the maximum baroclinic transport capacity of the strait is utilized.

My colleague's suggestion led to modelling results that were in better agreement with field measurements, but was the model accurate? More field measurements in the area would be required. When reviewing previous measurements, I was struck by how little information was available. Even reliable information concerning the bottom topography was lacking. Using research vessels from Umeå and the Göteborg Marine Research Centre, my research team has now made three expeditions to study salinity, temperature, and flow variations in the region. Our major findings are described in Green, Liljebladh and Omstedt (2006).

Water level affects exchange

The measurements made in the Northern Kvarf Strait showed an even more complex picture than our original model. We found that the exchange of water between Bothnian Bay and the Bothnian Sea is heavily influenced by variations in water level, primarily in the fall and winter. When water level determines the exchange, the water will flow either northward or southward throughout the entire sound. A full 90% of the exchange was attributable to these variations during two windy months in the fall of 2004. The flow rates were nearly the same at all depths (Fig. 3).

In addition to this highly variable water transport, we also observed the currents included in our original model, i.e. outflow from Bothnian Bay at the surface and inflow along the bottom from the Bothnian Sea. It thus appears to be true

that the Northern Kvarf Strait determines the flow into and out of Bothnian Bay, just as our model had predicted. But this is not the whole story. Salinity and flow rate increased almost linearly toward the bottom in the West Kvarf Strait, indicating that friction from the surface and bottom are important factors not yet included in our models. It is also not clear how the exchange of water differs between the West and East Kvarf Straits.

Observations needed

As is so often the case when dealing with the sea, field observations are essential to increase our understanding and ability to build realistic and usable models. Reality is also often more complex than we think. More detailed studies are needed, with new measuring programs and modelling studies. The Northern Kvarf Strait is truly one of the less understood regions of the Baltic Sea.

References

- Green, M., J. A., Liljebladh, B., and A., Omstedt (2006). Physical oceanography and water exchange in the Northern Kvarf Strait. *Continental Shelf Research*, 26, 721-732.
- Stigebrandt, A. (2001). Physical Oceanography of the Baltic Sea. Chapter 2 in: *A Systems Analysis of the Baltic Sea* (F. Wulff, L. Rahm and P. Larsson, eds.), Ecological Studies, Vol. 148, Springer Verlag.

Trends of temperature in the Baltic Sea for the period 1969-2005 and long-term variability in winter water mass formation

Andreas Lehmann (alehmann@ifm-geomar.de) and *Hans-Harald Hinrichsen* (hhinrichsen@ifm-geomar.de), *Leibniz Institute of Marine Sciences at the University of Kiel, Germany*

Introduction

The warming trend for the entire globe (1861-2002) is 0.05°C/decade. A specific warming period started around 1980 and has continued at least until 2006. The temperature increase of that period is about 1°C (0.4°C/decade). This trend has been equally well documented by observations and in climate simulations for many areas on the globe (Fig. 1). Consequently, this warming is evident also for the Baltic Sea catchment basin (BACC Author Team 2006, Lehmann and Tschersich 2006). Between 1960 and 1980, the air temperature for the catchment basin was close to or slightly below the long-term mean with respect to the period 1874-2004, only between 1965 to 1975 the temperature was slightly above the mean. Then, at the onset of the 1980s, temperatures increased by about 1°C until 2004 (Figure 3 in HELCOM 2007).



The Research Vessel Skagerack from Göteborg University enters the Northern Kvarf Strait. (Photo: Anders Omstedt)

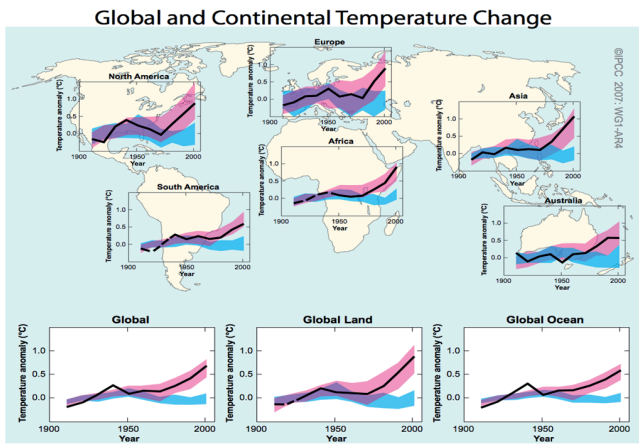

Fig. 1. Global and continental temperature change. Black lines represent observations, pink shaded areas IPCC climate model results with anthropogenic forcing, blue shaded areas climate model results without anthropogenic forcing (IPCC 2007)

SST trend for the Baltic Sea

Siegel et al. (2006) calculated a corresponding SST (sea surface temperature) trend with data obtained from NOAA satellites for the period 1990-2004 (see also Lehmann and Tschersich 2006). The trend was dominated by a temperature increase in summer and autumn, while in winter, a slightly negative trend resulted. These trends continued also in 2006. For the period 1990-2006, the SST warming closely followed the corresponding trend in the mean air temperature over the Baltic Sea catchment basin. MacKenzie and Schiedek (2007) calculated the warming trend of SST from 1 m water samples for the period 1870-2003. Since 1985, summer temperatures have increased nearly three-fold compared to the global warming trend. In the period from 1985-2002, summer temperatures have risen by 1.4°C, which is 2-5 times faster than in any other season.

Bulk temperature trend for the Baltic Sea

To investigate whether the warming of the surface is also apparent in deeper layers of the Baltic Sea, we analysed temperatures profile data compiled from the International Council for Exploration of the Sea (ICES) Oceanographic Database for the period 1969-2005. All available temperature data were selected in ICES subdivisions (SD) 24 to 30 (Fig. 2, Baltic proper including Arkona Sea and Bothnian Sea). The data of SD 31 and 32 (Bothnian Bay and Gulf of Finland) and were not used because during winter months, temperature profiles were temporally insufficiently resolved owing to sea ice coverage. Data were subsequently aggregated to obtain monthly means, with 5 m depth strata down to the bottom (see Hinrichsen et al. 2007 for details).

As an example of temperature data, Fig. 3 shows the temperature evolution for SD 28, the eastern Gotland Basin for the period 1969-2005. Down to about 70-90 m, the seasonal mixed layer development can be observed. Warm and cold summers

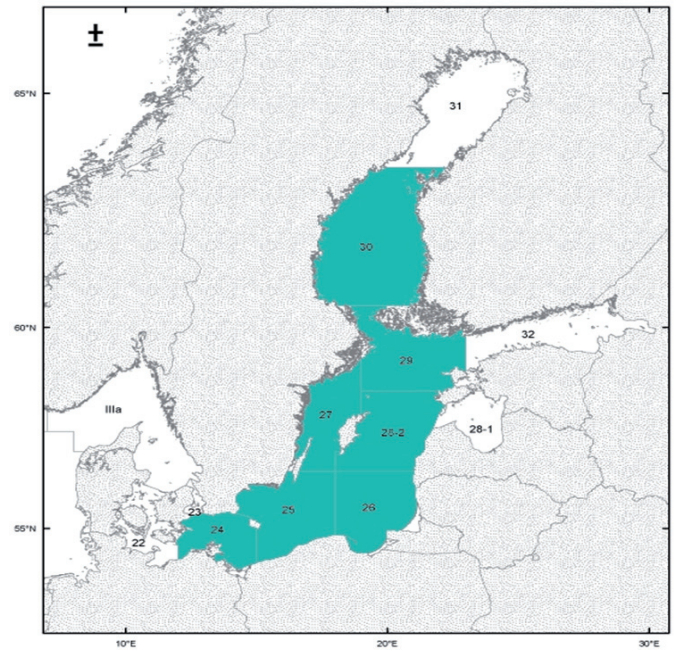

Fig. 2. Map of the Baltic Sea with ICES subdivisions

are apparent as well as mild and severe winters. The seasonal development reaches down to the permanent halocline.

Within and below the halocline (70-100 m), temperature changes are due to advective inflows from the Bornholm Basin. Abrupt changes appear in the wake of major Baltic Inflows. During the stagnation period from 1985-1994, the permanent halocline weakened and descended to larger depths, consequently, convective mixing during winter could reach larger depths.

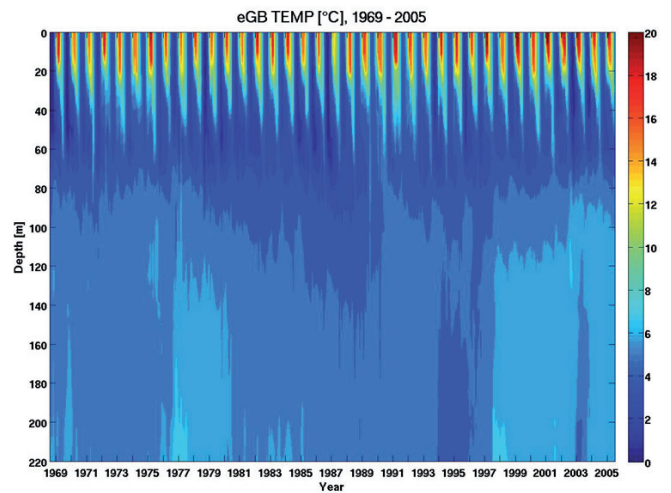

Fig. 3. Temperature evolution of the eastern Gotland Basin (SD 28) for the period 1969-2005, reproduced from data of the ICES oceanographic database

At least at the surface (5 m) the seasonal signal masks any temperature trend. Thus, we calculated the annual mean surface temperature for the period 1969-2005 (Fig. 4). At

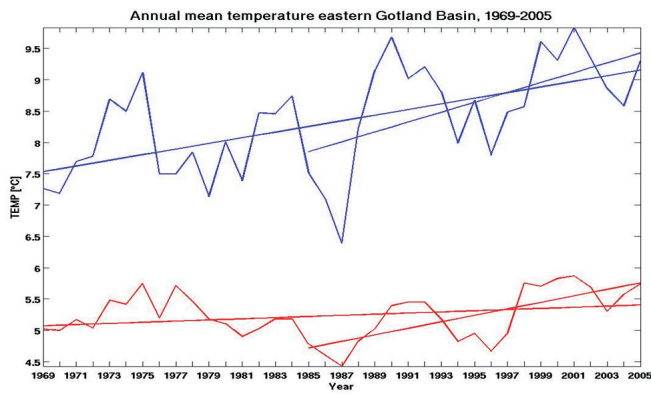

Fig. 4. Annual mean temperature for the eastern Gotland Basin, blue lines: surface temperature and linear trends for the period 1969-2005 and 1985-2005; red lines: vertical mean temperatures and linear trends for the period 1969-2005 and 1985-2005.

the surface, there is a high inter-annual variability visible. The linear trend calculated over the period 1969-2005 is $0.45^{\circ}\text{C}/\text{decade}$ and for the period 1985-2005 it is $0.8^{\circ}\text{C}/\text{decade}$. This agrees well with the results of MacKenzie and Schiedek (2007). The warming trend for the total water body averaged from the surface to the bottom reveals $0.09^{\circ}\text{C}/\text{decade}$ for the period 1969-2005, and $0.52^{\circ}\text{C}/\text{decade}$ for the period 1985-2005 (Fig. 4). Comparing the vertical averaged annual mean temperature of the eastern Got-

land Basin with the annual mean 2 m air temperature for the Baltic Basin (see Figure 3 in HELCOM 2007) reveals a strong similarity. We obtained similar warming trends also for the other subdivisions. Obviously, Baltic Sea bulk temperatures follow closely climatic trends in air temperature.

Hinrichsen et al. (2007) demonstrated a strong correlation between SST during winter months and mid-water temperatures until autumn months (Fig. 5). The strong coupling permits sea surface temperatures in winter to be used to forecast the seasonal development of the thermal signature in deeper layers with a high degree of confidence. The temporal temperature development in the interior of the Baltic Sea is coupled to atmospheric processes at the sea surface via winter water formation and horizontal advection. Furthermore, the significant relationship of SST and mid-water temperatures could have a considerable influence on the description and prediction of processes affecting the development, growth and survival of species representing different trophic levels (Hinrichsen et al. 2007).

References

- BACC Author Team (2006) BALTEX Assessment of Climate Change for the Baltic Sea Basin – The BACC Project – Summary. International Conference Göteborg, Sweden, 22-23 May 2006. International BALTEX Secretariat Publications No. 35, 16 pp.

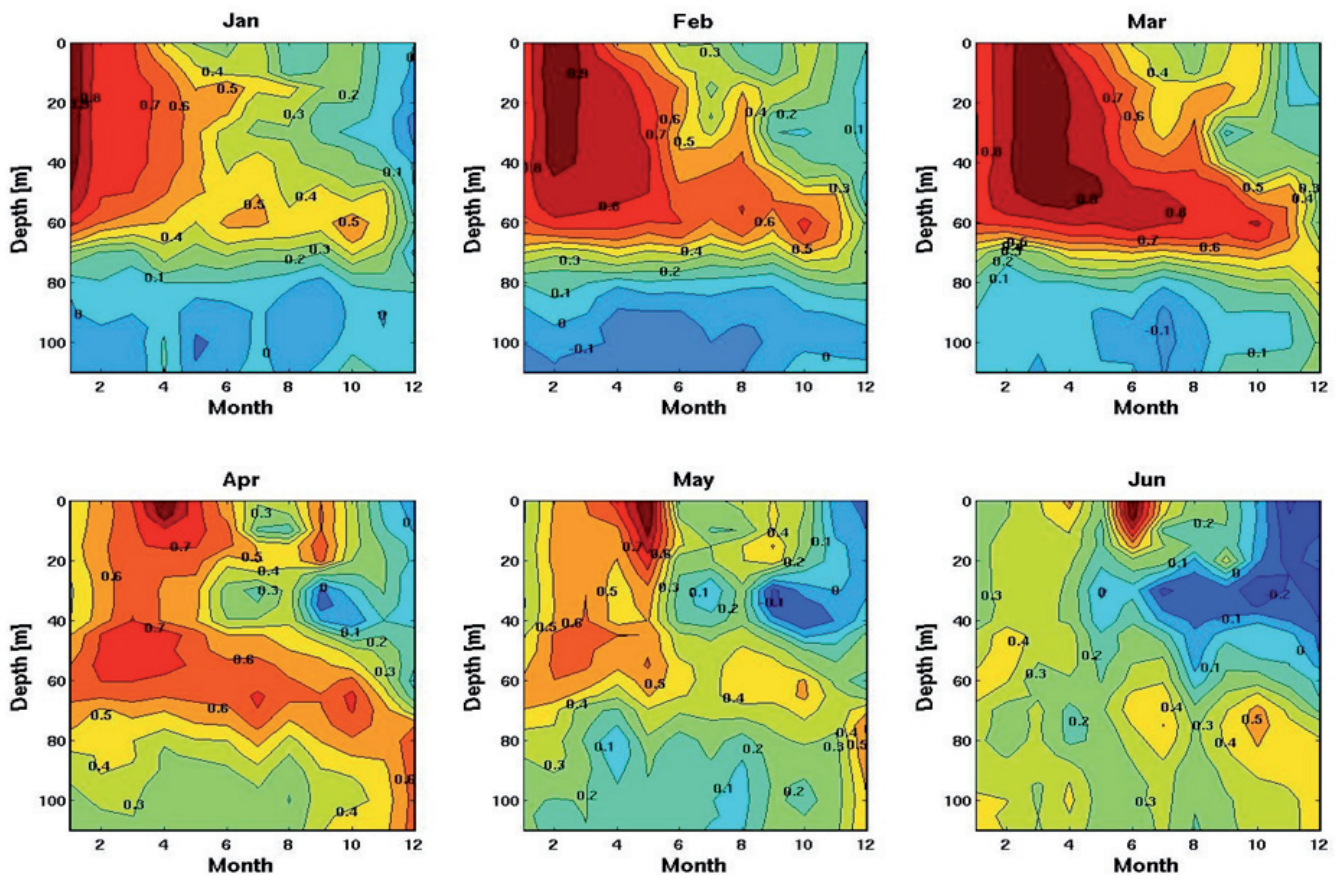

Fig. 5. Correlation coefficients between January and June SST and deeper water mass temperatures for all months at ICES SD 26 (Gdansk Deep). The high correlation coefficients (in red) demonstrate a strong linkage between surface and mid water temperatures.

HELCOM (2007) Climate Change in the Baltic Sea Area – HELCOM Thematic Assessment in 2007, Baltic Sea Environment Proceedings No. 111, 49 pp.

Hinrichsen, H.-H., Lehmann, A., Petereit, C., Schmidt, J. (2007) Correlation analysis of Baltic Sea winter water mass formation and its impact on secondary and tertiary production. *Oceanologia*, 49(3):1-15.

Lehmann, A., Tschersich, G. (2006) Trends in sea surface temperature of the Baltic Sea since 1990. *BALTEX Newsletter* No. 9.

MacKenzie, B. R., Schiedek, D. (2007) Daily ocean monitoring since the 1860s shows record warming of northern European seas. *Global Change Biology*, 13(7):1335-1347.

Siegel, H. Gerth., M., Tschersich, G. (2006) Sea surface temperature development of the Baltic Sea in the period 1990-2004. *Oceanologia* 48:119-131.

Simulations of the particulate organic carbon (POC) in the southern Baltic Sea, a Pilot Study

Lidia Dzierzbicka-Głowacka (dzierzb@iopan.gda.pl), Karol Kuliński and Janusz Pempkowiak, Institute of Oceanology, Polish Academy of Sciences, Sopot, Poland

A POC (Particulate Organic Carbon) model was coupled with a one-dimensional physical and biological upper layer model to simulate the particulate organic carbon fluxes in the southern Baltic Sea. The calculations were done for one year (1999) for a station in the Gdańsk Deep (southern Baltic Sea).

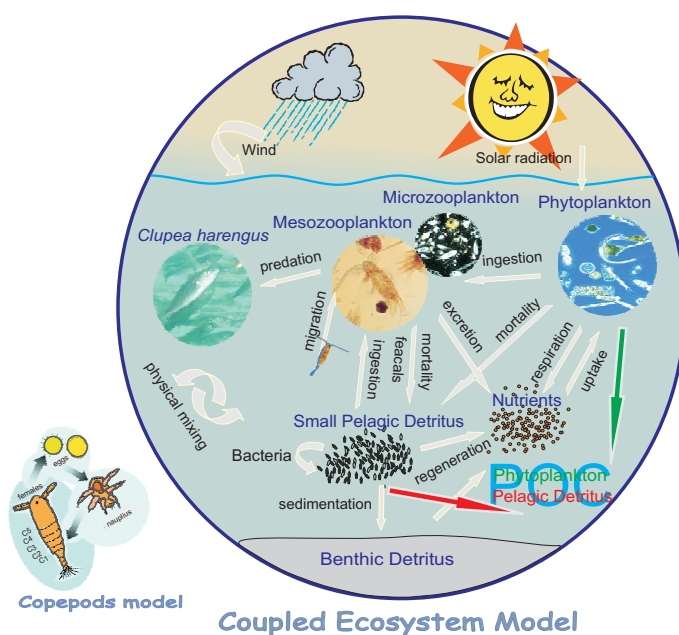

Fig. 1. Conceptual figure of the coupled model

The particulate organic carbon model

The seasonal dynamics of particulate organic carbon was obtained using the 1D-CEM with an equation for pelagic detritus (Fig. 1). The one-dimensional coupled ecosystem model consists of three submodels: a meteorological submodel for the physics of the upper layer, and a biological submodel which is also driven by the output of the physical submodel. The biological submodel combines three modules: a nutrient-phytoplankton-zooplankton-detritus module, a copepod module, and a simple prey-predator module. There are seven diffusion-advection reaction equations for phytoplankton, microzooplankton, pelagic detritus biomass, nutrient concentration, total mesozooplankton biomass, and early juvenile fish. The eighth equation, an ordinary differential equation, describes the development of detritus at the bottom.

The philosophy was to make the model as simple as possible, so it was based on the following assumptions: (i) We are modelling phytoplankton by only one state variable. The phytoplankton concentration is taken as a dynamically passive physical quantity, i.e. it is incapable of making autonomous movements. (ii) The model is based on total inorganic nitrogen ($\text{NO}_3 + \text{NO}_2 + \text{NH}_4$) and phosphate (PO_4). The nutrients serve both as a trigger and as a limiting agent for primary production. (iii) Organic detritus in the water column is either immediately remineralized or directly transported to the bottom, where it accumulates in a stock of benthic detritus. (iv) The concept of the detritus pool at the bottom has been introduced to create a lag in remineralization of the majority of detritus and the eventual replenishment of the upper layer with nutrients. This complex process is parameterized by assuming a net remineralization rate for bottom detritus. (v) One state variable for microzooplankton is considered. Microzooplankton is defined as heterotrophic planktonic organisms from 10 to 500 μm SED (Spherical Equivalent Diameter) excluding heterotrophic nanoflagellates and naupliar/larval stages of larger zooplankton and of benthic organisms. The microzooplankton comprises ciliates and other heterotrophic protists, which are filter-feeders, feeding on phytoplankton. (vi) The predator is represented by earlier juvenile of herring *Clupea harengus* for 4-10 cm size class, where its growth rate is controlled by the encounter rate between consumer and prey. (vii) In this model the mesozooplankton (herbivorous copepods) is represented by two species *Pseudocalanus minutes elongatus* and *Acartia spp.*, which are represented by 6 cohorts in different development stages.

The 1D-CEM is an open model which enables the study of: (1) annual, seasonal, monthly and daily variability of marine plankton and particulate organic carbon in the southern Baltic Sea, (2) the impact of various climatic conditions

over several years, and (3) the influence of different hydro-physical and biological processes on the vertical distributions of characteristics as a function of time.

In this paper, the particulate organic carbon concentration is determined as the sum of phytoplankton and pelagic detritus concentrations $POC(z, t) = Phyt(z, t) + PDetr(z, t)$. The equations, process formulations and parameter values of the ecosystem model are given by Dzierzbicka-Głowacka (2005, 2006). The temporal changes in the pelagic detritus concentration, $PDetr$, are affected by dead phytoplankton and zooplankton, fecal pellets, sedimentation, grazing by zooplankton and pelagic regeneration. However, the phytoplankton biomass, $Phyt$, is given by primary production, respiration, mortality and grazing by zooplankton and fish.

$$\frac{\partial PDetr}{\partial t} = \frac{\partial}{\partial z} \left(K_z \frac{\partial PDetr}{\partial z} \right) + MOR_D + FEC_D + MOR_D - w_d \frac{\partial PDetr}{\partial z} - ING_D - REMI_D$$

$$\frac{\partial Phyt}{\partial t} + w_z \frac{\partial Phyt}{\partial z} = \frac{\partial}{\partial z} \left(K_z \frac{\partial Phyt}{\partial z} \right) + PRE - RES - MOR_D - GRA$$

Results

The development of particulate organic carbon POC was exactly correlated with the development of phytoplankton and pelagic detritus. Generally, the greatest amounts of POC occurred in the upper 30 m layer, during periods of large biomass of algae. Concentrations of POC were characterized by the occurrence of two peaks in a year; at the turn of April and May (600 mgC m^{-3}) and in October (100 mgC m^{-3}), Fig. 2.

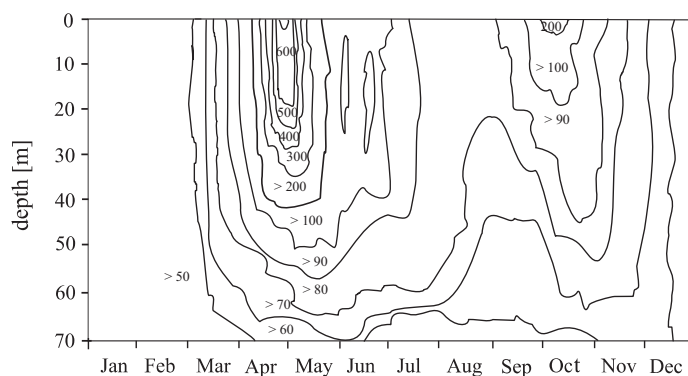

Fig. 2. Annual simulation – Particulate organic carbon [mgC m^{-3}]

During the period 1990-2006, samples were collected from selected depth in the Gdańsk Deep and analysed for both DOC and POC (Pempkowiak et al. 1984). For the purpose of this study, just POC data are used. Samples were collected by means of an all plastic bathometer from depths of 5, 30, and 70 m. Collected water was immediately transferred to glass bottles and immediately filtered through GF/F (Whatmann) glass fibre filters. Between 1.5 and 7.4 L of

the collected water passed through the filters under a suction of about 0.5 atm, before the flow was blocked. Filters were dried and stored until analyses on shore. The filters were analysed in a model CHN92 Carlo Erba CHN analyser. The results were recalculated into POC concentrations (mgC m^{-3}). Average values are presented in Fig. 3.

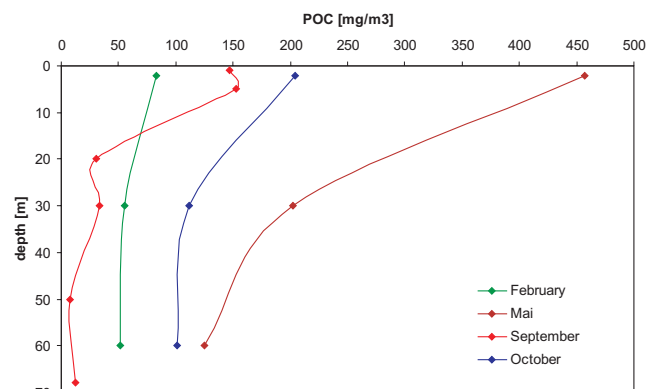

Fig. 3. Measured particulate organic carbon concentrations [mgC m^{-3}]

Model validation

Currently the described model is under validation. To this end, systematic measurements of POC concentrations in vertical profiles at stations situated at the Gdańsk Deep, and sporadic measurements at the Gotland Deep have been carried out. Measured and predicted concentrations agree reasonably well in the surface (0-30 m) layer, while the agreement in the subsurface water layer is much less obvious. This can be attributed to a variety of factors, including an import of POC to the study area.

References

- Dzierzbicka-Głowacka L. (2005) Modelling the seasonal dynamics of marine plankton in southern Baltic Sea. Part 1. A Coupled Ecosystem Model, *Oceanologia*, 47(4), 591-619
- Dzierzbicka-Głowacka L. (2006) Modelling the seasonal dynamics of marine plankton in southern Baltic Sea. Part 2. Numerical simulations, *Oceanologia*, 48(1), 41-71
- Pempkowiak J., Widrowski H., Kuliński W. (1984) Dissolved organic carbon and particulate organic carbon in the southern Baltic in September, 1983. Proc. XIV Conf. Baltic Oceanographers, Gdynia 1984, 699-713

Present seasonal variations of snow storage over Northern Europe

Lev Kitaev (lkitaev@online.ru), Institute of Geography, RAS, Moscow, Russia

Snow cover, winter temperature and precipitation over Northern Eurasia tend to increase (Kitaev et al. 2002). Against this background, a negative trend of snow gains is observed in November and December. Still, the snow gain in January shows a positive trend; the increment is 19 mm for the period 1966-2003. The snow gain in January makes the most essential contribution to a long-term increase of maximal winter snow storage. This process is connected to global warming which first of all influences snow accumulation in the autumn months, when temperatures approach 0°C.

In this article, long-term changes of monthly snow gains for Northern Europe (the Scandinavian peninsula and the East European Plain) are presented for the period 1961-2004. Regional snow storage is stable due to the condition of snow storage over the northern part of the East European Plain. Here, low air temperatures in winter bring about a positive trend in snow storage, with the maximum gain in December (13,9 cm and 0,18 cm / year). In Scandinavia, high winter temperatures cause a reduction of snow storage (Table 1).

Table 1. Linear trends of temporal variability of monthly gains of snow storage and air temperature for the period 1961-2004 (insignificant trends are marked with italics, highest trend values for each region are marked in red).

Region	Month	Snow depth (monthly gain)		Air temperature	
		β	R^2	β	R^2
Scandinavian peninsula	Nov	<i>0.19</i>	<i>0.08</i>	<i>0.04</i>	<i>0.01</i>
	Dec	-0.34	0.17	0.05	0.14
	Jan	-0.35	0.12	0.08	0.13
	Feb	-0.40	0.12	0.10	0.11
Northern part of the East European Plain	Nov	0.16	0.17	0.04	0.15
	Dec	0.18	0.13	0.03	0.12
	Jan	0.16	0.17	<i>-0.04</i>	0.15
	Feb	0.17	0.14	0.11	0.19
All territory	Nov	<i>0.02</i>	<i>0.02</i>	0.08	0.15
	Dec	0.07	0.01	0.09	0.17
	Jan	<i>-0.05</i>	<i>0.01</i>	<i>0.03</i>	<i>0.11</i>
	Feb	<i>-0.30</i>	<i>0.01</i>	<i>0.00</i>	<i>0.00</i>

Changes in the trend are governed by areas in which snow gains in December do not exceed the standard deviation. Fig. 1 illustrates the relative importance of the Scandinavian peninsula and the northern part of the East European Plain for determining the trend in snow accumulation in

northern Europe. Areas where snow cover and temperatures have extreme values at the same time are also evident in some years. These variations are not shown here as they are similar to those shown in Fig. 1, but do not exceed 15-20% of the total area. Values in excess of twice the standard variation were found in 1993 only. Consequently, the variability of extreme snow fall events do not contribute to the long term trends in snow storage increase. Extreme snow storage events in northern Europe decrease due to global warming.

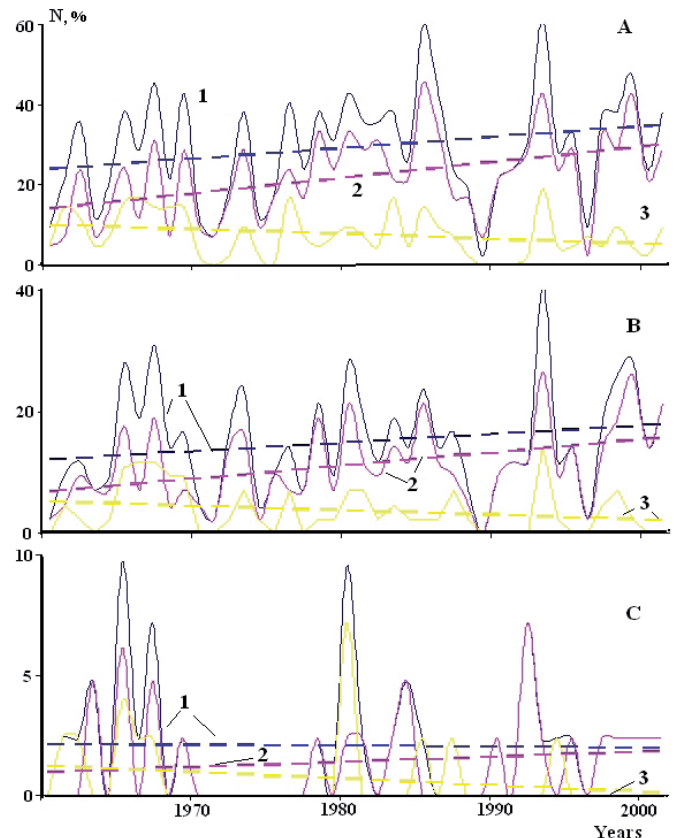

Fig. 1. Multi-year variability of the area (in % of total area) where snow storage in December (A) does not exceed half of the standard deviation, (B) exceeds the standard deviation, and (C) exceeds twice the standard deviation. – (curve 1, blue) represents the studied territory on the whole, (curve 2, pink) represents the northern part of the East European Plain, and (curve 3, yellow) stands for the Scandinavian peninsula. Dotted lines represent the respective linear trends.

Atmospheric circulation and snow storage variability are significantly correlated over Northern Europe. The Northern Arctic Oscillation and the Polar Oscillation have an essential influence on snow accumulation, with significant correlation coefficients (Popova 2004). Local atmospheric patterns according to the classification of Dzerdzevskii (1962) were also examined (Table 2). The correlation between snow gain and the number of meridional northern and southern types of circulation is negative in autumn: temperatures are too high for excessive snow accumulati-

on. In January and February, the transport of precipitation (southern meridional circulation) and the cold meteorological regime (northern meridional circulation) ensure stable snow accumulation.

Table 2. Correlations between variabilities of monthly snow gains and types of atmospheric circulation

Month	Monthly snow gains vs. types of atmospheric circulation	Correlation	
		R	R ²
Nov	Snow gain vs. Northern meridional	-0.301	0.091
Dec	Snow depth vs. Southern meridional	-0.316	0.099
Jan	Snow gain vs. Southern meridional	0.366	0.134
Feb	Snow gain vs. Northern meridional	0.417	0.175

References

- Dzerdzeevskii, B. (1962) Fluctuations of Climate and of General Circulation of the Atmosphere in extra-tropical latitudes of the Northern Hemisphere and some problems of dynamic climatology. *TELLUS*. XIV (3), 328-336
- Kitaev, L., A. Kislov, A. Krenke, V. Razuvaev, R. Martuganov and I. Konstantinov (2002). The snow cover characteristics of Northern Eurasia and their relationship to climatic parameters. *Boreal Environment Research* 7 (4), 437-446
- Popova, V. (2004) Structure of long-term fluctuations of snow depth in Northern Eurasia. *Russian Meteorology and Hydrology* 8, 21-34

Evaluation of Rossby Centre RCA3 cloud climate simulations over Scandinavia using a ten-year NOAA AVHRR cloud climatology

Karl-Göran Karlsson (karl-goran.karlsson@smhi.se) and **Ulrika Willén** (ulrika.willen@smhi.se), Swedish Meteorological and Hydrological Institute, Norrköping, Sweden

Introduction

The simulation of clouds and the description of their impact on radiation processes are important and critical components of the climate modelling process. Consequently, model validation experiments where simulations are compared to observed cloud and radiation conditions are essential. So far, validation of cloud simulations of the Rossby Centre regional atmospheric climate model (RCA) has been based on ground-based cloud radar and cloud lidar measurements from a few observation sites (Willén et al. 2005, and Illingworth et al. 2007). We present here some

results from a model validation experiment utilising the long-term (1991-2000) satellite NOAA-AVHRR cloud climatology data set SCANDIA over the Scandinavian region (Karlsson 2003) to evaluate the RCA3 climate simulation model (Kjellström et al. 2005). From these results it would be possible to confirm previously achieved results, and whether they apply to larger geographical regions.

Methodology

We have evaluated the following three important aspects of cloud appearance:

- Fractional total cloud cover
- The vertical distribution of clouds
- The optical thickness of clouds

Several methods of adapting the satellite and model datasets to enable a fair comparison were applied, explained in detail by Karlsson (2006) and Karlsson et al. (2007). One aspect was to account for the fact that the satellite sensor is not capable of detecting optically very thin clouds from the space-based platform (thus, an optical thickness cutoff has to be applied to model datasets). Other aspects have been to simulate the space observation geometry from the model dataset and to apply the same cloud overlap assumption (maximum) to results as is used in the RCA3 radiation scheme.

The evaluated model dataset was produced in a perfect boundary climate simulation experiment (i.e. a simulation of the present climate with analysed boundary fields). The model was run using ECMWF re-analysis fields (ERA-40) for specifying the lower and lateral boundary conditions. The RCA3 horizontal grid resolution was approximately 50 km and the number of vertical levels was 24.

Results

The study resulted in the following main conclusions:

- RCA3 appears to produce quite reasonable amounts of total cloud cover (i.e. within a few percent compared to SCANDIA) on seasonal and annual time scales during this period (Table 1).
- A substantial imbalance between the respective RCA3 contributions from low-, medium- and high-level clouds is seen. The differences from SCANDIA contributions were +2.4 % for high-level clouds, -5.2 % for medium-level clouds and +4.0 % for low-level clouds (Table 2 and Figure 1).
- An over-representation of cloud categories with high optical thicknesses is seen for all vertical cloud groups. For full illustration see Karlsson (2005) and Karlsson et al. (2007).

Table 1. Area mean of seasonal total cloud cover (%) for RCA3 and SCANDIA after applying optical thickness cutoff. The mean difference (bias) and RMS difference is also shown together with the corresponding difference without applying optical thickness cutoff (in brackets).

	RCA3	Scandia	Bias	RMS
Winter	64.31	71.47	-7.16 (-2.72)	9.96 (7.23)
Spring	59.48	64.41	-4.93 (-1.40)	7.00 (5.07)
Summer	61.58	58.75	2.83 (3.88)	5.65 (6.38)
Autumn	67.18	67.35	-0.17 (2.09)	5.48 (5.83)
Annual	63.14	65.50	-2.36 (0.46)	7.02 (6.13)

Table 2. Area mean of seasonal (excluding Winter) differences (bias) between RCA3 and SCANDIA for high-level, medium-level and low-level cloud amount contributions (%). Corresponding differences without applying optical thickness cutoff are shown in brackets.

	Bias high-level clouds	Bias medium-level clouds	Bias low-level clouds
Spring	3.39 (5.69)	-7.01 (-6.55)	0.61 (1.12)
Summer	5.58 (6.39)	-4.92 (5.04)	4.92 (5.04)
Autumn	-1.84 (-0.54)	-2.86 (-2.70)	6.48 (6.87)
Annual excl. Winter	2.38 (3.85)	-5.19 (-4.98)	4.00 (4.37)

Discussion

The consequences for RCA3 simulations of radiation conditions are expected to have the largest impact for surface radiation budget components, i.e. by reducing incoming solar radiation and increasing down-welling long wave radiation. Such effects have been confirmed in separate validation studies where an underestimated diurnal cycle of surface temperatures in RCA3 was found (Kjellström et al. 2005). This is mainly a consequence of the overestimated optical thicknesses of clouds which implies an excess of cloud condensate in RCA3-simulated clouds. Implications for top-of-atmosphere radiation budget components are more uncertain since results indicate some counterbalancing effects.

Results generally agree well with previous results by Wilén et al. (2005) and Illingworth et al. (2007). Thus, their findings appear to be valid also over larger geographical domains (Scandinavia). In addition, results appear to have large similarities to those achieved in corresponding satellite-based validation studies of global climate model simulations (Zhang et al. 2005).

An additional feature seen in this study is an unrealistic distribution of cloudiness over and in the vicinity of the Scandinavian mountain range (partly visible in Figure 1, espe-

cially for high-level clouds). In particular, excessive cloud amounts are found over the Scandinavian mountain range for all seasons and for all vertical cloud groups studied. Simultaneously, a deficit in cloud amount is seen lee-ward (e.g. to the east) of the mountains which exists more or less pronounced along the whole extension of the Scandinavian mountain range. Results from additional experiments, where the horizontal grid resolution was improved from 50 km to 25 km, showed significant improvements in the simulated cloud distribution. These results point at the importance of having steep and complicated orography better resolved for being able to get reasonable simulations of the flow surpassing mountains and for improving the description of orographically induced clouds and precipitation.

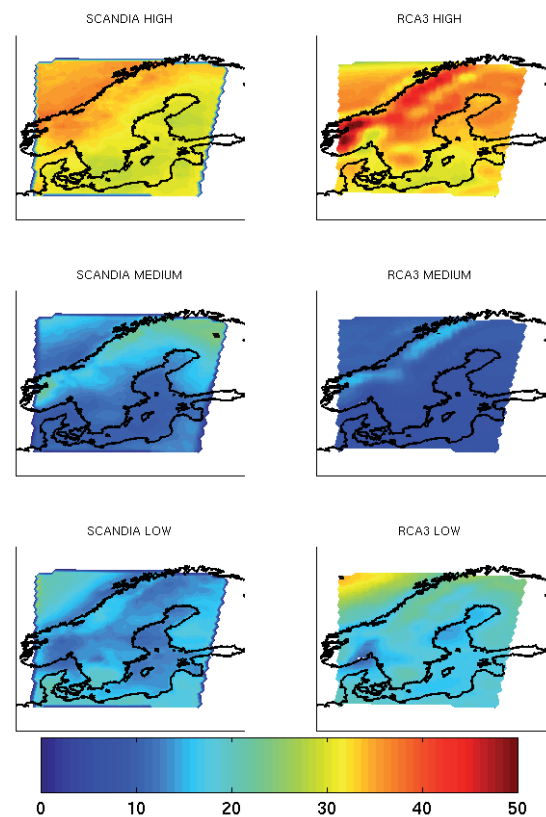

Figure 1. Annual mean (excluding Winter) 1991-2000 of the high-level (upper panels), medium-level (middle panels) and low-level (lower panels) cloud cover contribution to the satellite-viewed total cloud cover (%) for SCANDIA compared with RCA3 simulations. Results are shown after applying optical thickness cutoff on RCA3 results.

Further modelling experiments and validation efforts must be made to get a deeper understanding of the performance of RCA3 cloud and radiation description. For the future, we hope that the developed model validation methodology can be used in additional studies for testing future upgraded RCA model versions. However, more important is the opportunity to extend the methodology to be based on

new and enhanced satellite-based climatological datasets, such as the data set from the Climate Monitoring SAF project (CM-SAF, introduced by Schulz et al. (2005)), covering a much larger geographical area. This would enable a more comprehensive evaluation and comparison of results from both regional and global cloud climate simulations. A first attempt of using CM-SAF data for model validation purposes has been initiated.

A full description of the model validation experiment and a more complete discussion of the results are given by Karlsson (2006) and Karlsson et al. (2007).

References

- Illingworth et al. (2007) CLOUDNET – Continuous evaluation of cloud profiles in seven operational models using ground-based observations. Bull. Amer. Meteorol. Soc., accepted
- Karlsson, K.-G. (2006) The use of a satellite-derived cloud climatology for studying cloud-aerosol processes and the performance of regional cloud climate simulations, Ph. D. Thesis, Stockholm University, ISBN 91-7155-353-3.
- Karlsson, K.-G., U. Willén, K. Wyser and C. Jones (2007) Evaluation of regional cloud climate simulations over Scandinavia using a ten-year NOAA AVHRR cloud climatology, submitted to Journal of Geophysical Research-Atmospheres.
- Kjellström, E. et al (10 named authors) (2005) A 140-year simulation of European climate with the new version of the Rossby Centre regional atmospheric climate model (RCA3). SMHI Reports Meteorology and Climatology, No. 108.
- Schulz, J. et al (16 named authors) (2005) Operational climate monitoring from space: The Satellite Application Facility on Climate Monitoring. Proc. NOAA 29th Annual Climate Diagnostics and Prediction Workshop October 18-22, 2004, Madison, Wisconsin.
- Willén, U., Crewell, S., Baltink, H. K. and O. Sievers (2005), Assessing model predicted vertical cloud structure and cloud overlap with radar and lidar ceilometer observations for the Baltex Bridge Campaign of CLIWA-NET. Atmos. Res., 75, 227-255.
- Zhang, M.H. et al (20 named authors) 2005: Comparing clouds and their seasonal variations in 10 atmospheric general circulation models with satellite measurements. J. Geoph. Res., 110, D15S02, doi: 10.1029/2004JD005021.

Storm surges on the southern coast of Gulf of Riga

Tatjana Koltsova (tatjana.kolcova@lvgma.gov.lv), **Jelena Belakova** (jelena.belakova@meteo.lv), Latvian Environment, Geology and Meteorology Agency, Riga, Latvia

Introduction

The Lielupe River basin covers approximately 17,600 km² of which 8,800 km² is in Latvia and 8,800 km² in Lithuania. Lielupe River has an annual water runoff of 3,370

Million m³ to the Gulf of Riga. The length of the main stream is approx. 285 km, of which 133 km are in Latvia. The Lielupe is the second largest river in Latvia.

The river has two major tributaries: Musa River (165 km of length) and Memele River (182 km of length). 13 km from the border between Latvia and Lithuania, the Musa River merges with the Memele River at an elevation of 12 m above sea level to become the Lielupe River. In this stretch, the river is 94 m wide and 0,5 m deep. The Lielupe River is navigable at 16 km downstream of this confluence. In Jelgava, the river is only 2.5 m above sea level; its width is about 200 m and its depth is more than 2.5 m. Downstream Jelgava, the river forms a typical estuary with riverbanks, small islands and peninsulas, swamps etc. Downstream from here, the slope of the river is 5-10 cm/km, and the high water levels in the Gulf of Riga have a damming effect on the flow of the river. The level of the river bed is much lower than the average Baltic Sea level over a length of 100 km upstream from the mouth. As a result, water flows upstream through backwaters in autumn and winter. The highest backwater flooding event in an observation period of 80 years was in 1969 and was driven by the wind.

The Lielupe River basin is the driest region in Latvia, with a precipitation between 550 and 670 mm per year, of which more than 50% evaporates. The average temperature is about 17 – 18 °C in July and about -5 °C in January. The dominating wind is south-westerly (Lielupe River Basin Management Plan 2001).

In the period 1969-1984, specialists of the River Mouth Station carried out water flow and salinity measurements. (Reports of RMS, 1969-1985). The study demonstrates that sea water flows up the river mouth and sometimes reaches the Kalnciems region (~ 50 km upstream). The entire water

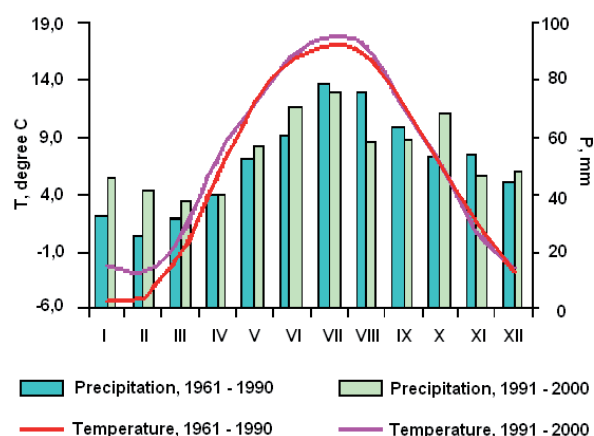

Figure 1. Regional data series of temperature (line) and precipitation (column) for the reference period 1961-1990 and the last decade

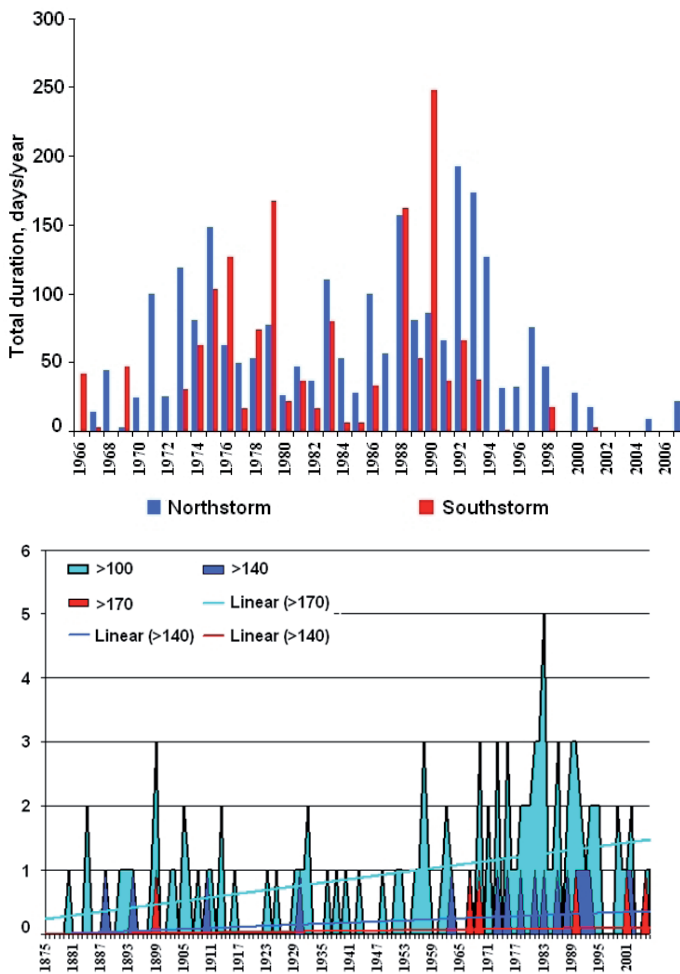

Figure 2. Duration of northern and southern storms (24-hour speed > 8 m/s) in the south of the Gulf of Riga for the period 1966-2006 (upper panel), and changes in frequency of extreme water levels in Lielupe River mouth for the period 1875-2006 (lower panel).

mass of Lielupe River flows downstream only during flood periods due to rainstorms and snow melt in spring. Also, periodic water level fluctuations should be considered. The water level rises during 12 hours and falls during about 12.8 hours (Pastors 1976). The height of the tide is 10 cm on average during the open channel period, and about 9 cm during freezing. This regime lasts 1-2 months and is normally interrupted by storm surges. The water mass circulation in water discharge is about 15 m³/s.

In the surface layer, the inflow velocity is 16 cm/s near the mouth (Priedaine bridge), 5 cm/s in the Kalnciems region (50 km upstream), but insignificant in deeper layers. The outflow velocity reaches 18-19 cm/s in the river mouth and about 10 cm/s in the Kalnciems region. The thickness of the layers is dependent on the water runoff.

During a period of 3.5 hours, when the water flow changes direction from inflow to outflow, its mean velocity is less than 1 cm/s. For these 3.5 hours, the water travels only 63 m downstream and back upstream. So, the water does not

effectively move two times per day, and the pollution load increases significantly. During low flow periods in summer and winter, the water quality conditions become critical because of the increasing oxygen demand and decreasing oxygen content (Report of LATGIPROM, 1977). Storm surges facilitate the exchange of the water masses and thereby improve the water quality. The aim of the present study is to evaluate the changes in water level and flow data series of Lielupe River with respect to climate change.

Data and methods

Monthly data series of precipitation and air temperature from three Lithuanian meteorological stations and four Latvian observation stations for the period 1941 to 2006 were used. Wind speed analyses were based on daily data series for the period 1966 to 2006. Wind gust data series from the Riga station cover the period 1941 to 2006. Surges in the Lielupe River are caused by the water mass exchange between the Baltic Sea and the Gulf of Riga, the wind speed and direction. To estimate the changes in the peak values of surges, a comparison of the water level data series from the different stations in the river mouth stretch was made. A Mann-Kendal test was used to evaluate changes in maximum and average water levels during the summer season for the period 1923-2006. The non-parametric Sen's Method was used to estimate the trend of storm wind durations for the period 1966-2006. For evaluating changes in the relationship between wind speed and storm water level, wind gust data of the Riga station and maximum water level data of Lielupes Griva station were normalized with reference to the period 1961-1990, by subtracting the mean and dividing with the standard deviation.

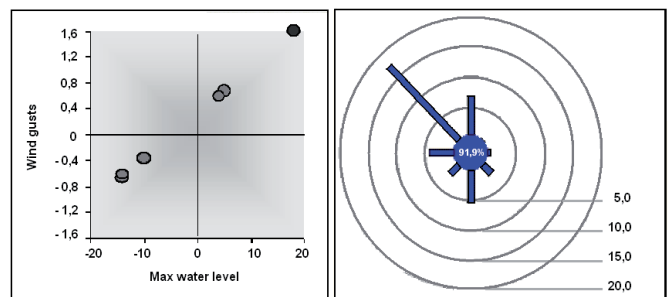

Figure 3. Anomalies (left) from the 1961-1990 reference value (lines) of storm gusts (Y axis, standard deviations) versus maximum water level in the river mouth (X axis, standard deviations) for the decades during 1941-2000 (gray dots) and 2001-2007 (black dot) and Wind Rose of maximum wind by "Clidata-Latvia" (right).

Results and discussion

Climate change is manifest in the significant increase of annual, winter and spring air temperature, which is in accordance with the results of an analysis of temperature and precipitation made in 2005-2006. The annual amount of

precipitation has increased since 1945, and so has winter precipitation since the beginning of the last century. Warm and unstable winters, decreasing spring floods and increasing winter runoff are typical of the last decade. Fig. 1 shows a comparison of regional precipitation and temperature data for two different periods.

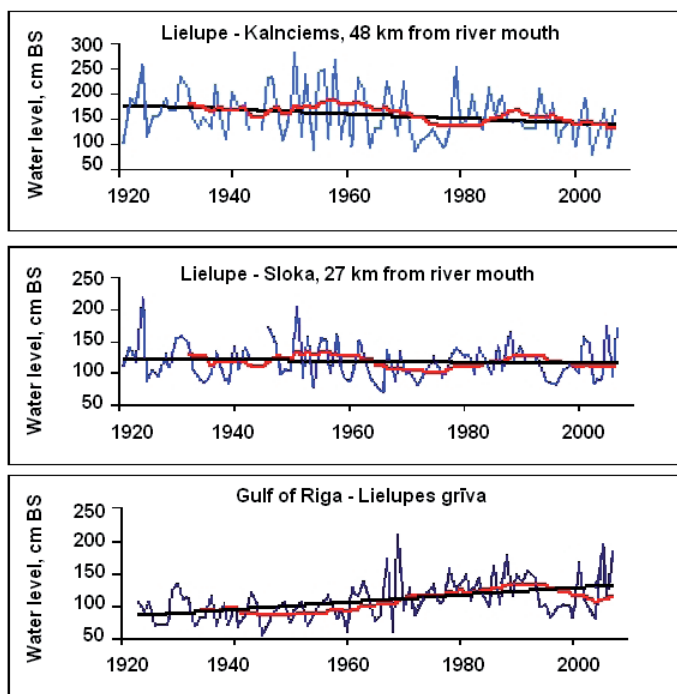

Figure 4. The trend of maximum water level in the mouth of the Lielupe River for period 1923- 2006: black line – regression line for gauge observations, red curve – 12-year running mean of gauge observations.

Storm surges at the southern coast of the Gulf of Riga, especially in the mouth of Lielupe River, are caused by storm winds and a water mass exchange between the Baltic Sea and the Gulf of Riga (Iljina et al. 1976, Pastors 1965). Mostly, northern to northwestern winds were recorded during surges. An analysis of daily wind speeds shows a decreasing occurrence of storms with a daily average wind speed of higher than 8 m/s. The Sen's slope for the north storm duration was calculated as -0,7, while it was -0,5 for the south storm duration (Fig. 2). Actually, maximum water levels in storm surges strongly depend on wind gusts (Fig. 3). During the recent two storm surges in 2005 and 2007, wind gusts of a speed of 30 and 28 m/s were recorded, respectively. A comparison of maximum water levels (Fig. 4) showed considerable differences between the trends in sea water level (Lielupe grīva station) and the river water levels (Kalnciems and Sloka stations). The process seems to be periodic with roughly a 40 year period in the river water level and an 80 year period in the sea water level. Moreover, only maximum sea water levels have increased; 48 km upstream from the river mouth, the

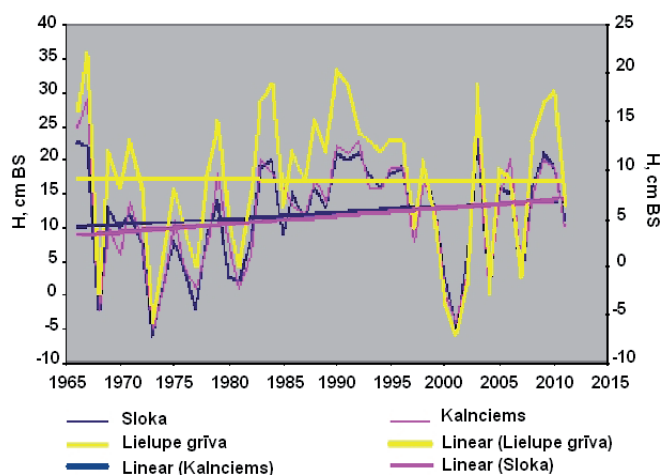

Figure 5. Average water level and linear trend lines of summer low flow period (June-September).

maximum water level has decreased due to a decrease of spring floods.

Considering the water quality problems of Lielupe River during low flow periods, the average summer water levels were analyzed (Fig. 5). Evidently, the water level in Sloka and Kalnciems in summer is not so much dependent on the sea water level. Significant positive trends were found in Sloka and Kalnciems, but no trend was evident in the sea water level series (Lielupe grīva station).

Conclusions

- Northern and northwestern winds form storm surges in the mouth of Lielupe River;
- The number of days with 24-hours average wind speeds higher 8 m/s decreases, but the number of storm gust events increases;
- There is a linear correlation between the maximum water level in the mouth of the Lielupe River and storm gust speeds south of the Gulf of Riga. Wind gust indices during the short period 2001-2007 were 1.6 standard deviation above the reference wind gusts of the period 1961-1990;
- Maximum water levels at Lielupe grīva station show a significant positive trend during the period 1923-2006, but the data series of Sloka station (27 km upstream from the mouth) show no trend at all, while the data series of Kalnciems station (48 km upstream from the mouth) show a significant negative trend. So, the river stretch effected by backwater becomes longer;
- The average water levels of low flow period (June-September) is increasing in Sloka and Kalnciems but has not changed in the mouth. As a result, the pollution load in the Lielupe River mouth during low flow period caused by tides is reduced, and the water quality is improving.

References

- Annual reports of Rigas Mouth Station (1969-1985), Riga
- Iljina J., Pastors A. (1976) Surges and ebbs in Gulf of Riga. Collection of scientific papers of Riga Hydrometeorological Observatory, 15, Riga (in Russian)
- Lielupe River basin management plan (2001). Analysis of situation. Latvia-Lithuania
- Pastors A. (1965) Surges and ebbs in downstretch of Lielupe River. Collection of LATNIIG&M, 3, Riga (in Russian)
- Pastors A. (1976) Water periodical circulation on the mouth stretch of Lielupe River. Collection of scientific papers of Riga Hydrometeorological Observatory, 15, Riga (in Russian)
- Report of LATGIPROM (1972) 2nd Edition, Riga (in Russian)

Recent BALTEX Publications

The International BALTEX Secretariat maintains a list of BALTEX publications, which is accessible via the BALTEX web site (www.baltex-research.eu). The most recent publications, generally younger than a year, are brought to your attention in the BALTEX Newsletter. To be qualified as BALTEX publication, BALTEX is explicitly referred to in the title, abstract, introduction or summary, or the authors have qualified their work as BALTEX publication. The reader is encouraged to contact the BALTEX Secretariat in case of missing or new BALTEX publications.

Bhend, J., H. v. Storch

Consistency of observed winter precipitation trends in northern Europe with regional climate change projections

Accepted in 2007 for publication in *Climate Dynamics*
Lead Author: Jonas Bhend, jonas.bhend@gkss.de

Hünicke, B., E. Zorita

Trends in the amplitude of Baltic Sea level annual cycle
Tellus A (OnlineEarly Articles). doi:10.1111/j.1600-0870.2007.00277.x, October 2007

Lead Author: Birgit Hünicke, birgit.huenicke@gkss.de

Meier, H. E. M.

Modeling the pathways and ages of inflowing salt- and freshwater in the Baltic Sea

Estuarine, Coastal and Shelf Science, Vol 74, No 4, pp 610-627, September 2007

Lead Author: H. E. Markus Meier, markus.meier@mhi.se

Suursaar, Ü., R. Aps

Spatio-temporal variations in hydro-physical and -chemical parameters during a major upwelling event off the southern coast of the Gulf of Finland in summer 2006.

Oceanologia, no 49(2), pp. 209-228, 2007

Lead Author: Ülo Suursaar, Ys@sea.ee

MacKenzie, B., H. Gislason, C. Möllmann, F. W. Köster

Impact of 21st century climate change on the Baltic Sea fish community and fisheries

Global Change Biology Vol. 13, No. 7, pp. 1348–1367

Lead Author: B. MacKenzie, brm@difres.dk

Makynen, M. P. Cheng, B. Simila, M. H. Vihma, T. Hallikainen, M. T.

Comparisons Between SAR Backscattering Coefficient and Results of a Thermodynamic Snow/Ice Model for the Baltic Sea Land-Fast Sea Ice

IEEE Transactions on Geoscience and Remote Sensing, Vol. 45, Issue 5, pp. 1131-1141, 2007

Lead Author: M. Mäkynen, marko.makynen@tkk.fi

Suursaar, Ü. and J. Sooäär

Decadal variations in mean and extreme sea level values along the Estonian coast of the Baltic Sea

Tellus A, Vol. 59, Issue 2, March 2007, pp. 249-260.

Lead Author: Ülo Suursaar, Ys@sea.ee

Beyrich, F. and W. K. Adam

Site and Data Report for Lindenberg Reference Site in CEOP - Phase I

Berichte des Deutschen Wetterdienstes, Vol 230, 2007

Lead Author: F. Beyrich, frank.beyrich@dwd.de

Suursaar, Ü., T. Kullas

Influence of wind climate changes on the mean sea level and current regime in the coastal waters of west Estonia, Baltic Sea

Oceanologia, no 48(3), 2006, pp. 361-383

Lead Author: Dr. Ülo Suursaar, Ys@sea.ee

Pirazzini, R., T. Vihma, M. A. Granskog, and B. Cheng
Surface albedo measurements over sea ice in the Baltic Sea during the spring snowmelt period

Ann. Glaciol., November 2006, 44, pp. 7-14

Lead Author: R. Pirazzini, roberta.pirazzini@fimr.fi

Cheng, B., T. Vihma, R. Pirazzini, and M. A. Granskog
Modelling of superimposed ice formation during the spring snow melt period in the Baltic Sea

Ann. Glaciol., 44, November 2006, pp. 139-146

Lead Author: B. Cheng, Bin_Cheng@fimr.fi

www.baltex-research.eu/publications

Conference Announcements

**European Geosciences Union
General Assembly 2008
Vienna, Austria
13 - 18 April 2008**



The entire spectrum of geosciences will be presented at the conference. BALTEX relevant sessions are

- Atmospheric Sciences (AS)
- Biogeosciences (BS)
- Climate: Past, Present, Future (CL)
- Hydrological Sciences (HS)
- Ocean Sciences (OS)
- Natural Hazards (HS)

Deadlines

Abstracts: 14 January 2008

Pre-registration: 31 March 2008

For more information and registration, see

<http://meetings.copernicus.org/egu2008/>

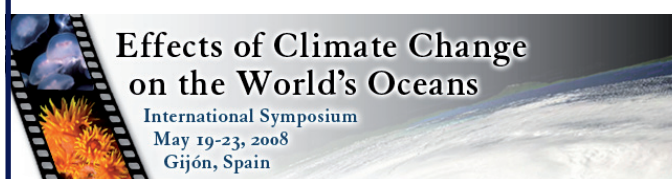

The Symposium will focus on the major issues of climate change that affect the oceans: oceanic circulation, climate modelling, cycling of carbon and other elements, acidification, oligotrophy, changes in species distributions and migratory routes, sea-level rise, coastal erosion, etc. The Symposium will bring together results from observations, analyses and model simulations, at a global scale, and will include discussion of the climate change scenarios and the possibilities for mitigating and protecting the marine environment and living marine resources.

Deadlines

Abstracts and early registration: 16 December 2007

For more information and registration, see

http://www.pices.int/climate_change.aspx

ICCP

**15th International Conference on
Clouds and Precipitation (IPPC 2008)
Cancun, Mexico, 9 - 13 July 2008**

Submissions on all research topics related to clouds and precipitation are welcome, such as

- Microphysics of clouds and precipitation
- Cloud dynamics and structure
- Modeling of cloud processes and parameterizations
- Aerosol-cloud interactions
- Cloud-chemistry interactions
- Instrumentation for cloud physics research
- Applications of cloud physics
- Cloud-climate interactions

Deadlines

Abstracts: 1 December 2007

Submission of papers: 1 March 2008

Early registration: 1 May 2008

For more information and registration, see

<http://convention-center.net/iccp2008/>



... at the FAO, Rome, Italy, 8 - 11 July 2008

The central goals of the symposium are to share experiences across disciplines and to identify key next steps and common elements and approaches that promote resilience of marine social-ecological systems in the face of global changes. This involves exploring social-ecological responses in marine systems to global changes; analysing case studies; synthesising the work of natural and social scientists; developing innovative approaches to science and knowledge in management, policy and advice; identifying lessons for governance for building resilient social-ecological systems.

Deadlines

Abstracts: 1 January 2008

Early registration: 1 April 2008

For more information and registration, see

<http://www.peopleandfish.org>

BALTEX is the European continental-scale experiment within the Global Energy and Water Cycle Experiment (GEWEX). It constitutes a research programme focussing on water and energy cycles in the climate system of the entire Baltic Sea basin with contributions of more than 10 countries. GEWEX has been launched by the World Meteorological Organisation (WMO), the International Council for Science (ICSU) and UNESCO's Intergovernmental Oceanographic Commission (IOC), as part of the World Climate Research Programme (WCRP). The scientific planning of BALTEX is under the guidance of the BALTEX Science Steering Group. The BALTEX *Newsletter* is edited and printed at the International BALTEX Secretariat with financial support through the GKSS Research Centre Geesthacht, Germany. It is the hope that the BALTEX *Newsletter* is accepted as a means of reporting on plans, meetings and work in progress, which are relevant to the goals of BALTEX, as outlined in the Science and Implementation Plans for BALTEX.

The editor invites the scientific community to submit BALTEX-related contributions to be published in this *Newsletter*. Submitted contributions will not be peer-reviewed and do not necessarily reflect the majority's view of the BALTEX research community. Scientific material published in this *Newsletter* should not be used without permission of the authors.

Please, send contributions to the BALTEX *Newsletter*; requests for BALTEX - related documents, suggestions or questions to the International BALTEX Secretariat via



www.baltex-research.eu

GKSS Forschungszentrum Geesthacht GmbH
International BALTEX Secretariat
c/o Dr. Hans-Jörg Isemer
Max-Planck-Str. 1
D - 21502 Geesthacht
Germany
Phone: +49-4152-87-1661
Fax: +49-4152-87-1730
e-mail: baltex@gkss.de or isemer@gkss.de

Order Form

Change of Address

Please send the BALTEX Newsletter to the following address:

Name: _____

Organisation: _____

Mailing Address: _____

City: _____

Country: _____

Telephone: _____

Fax: _____

E-Mail: _____